

Instruction manual and data sheet bPCA-3000-05-10-1550-x

Photoconductive THz antenna for laser excitation wavelengths $\lambda \sim 1550$ nm

PCA – Photo Conductive Antenna

Table of contents:

1. Spectral performance	2
2. Antenna parameters	3
3. Antenna design.....	4
4. Order information.....	5



1. Spectral performance

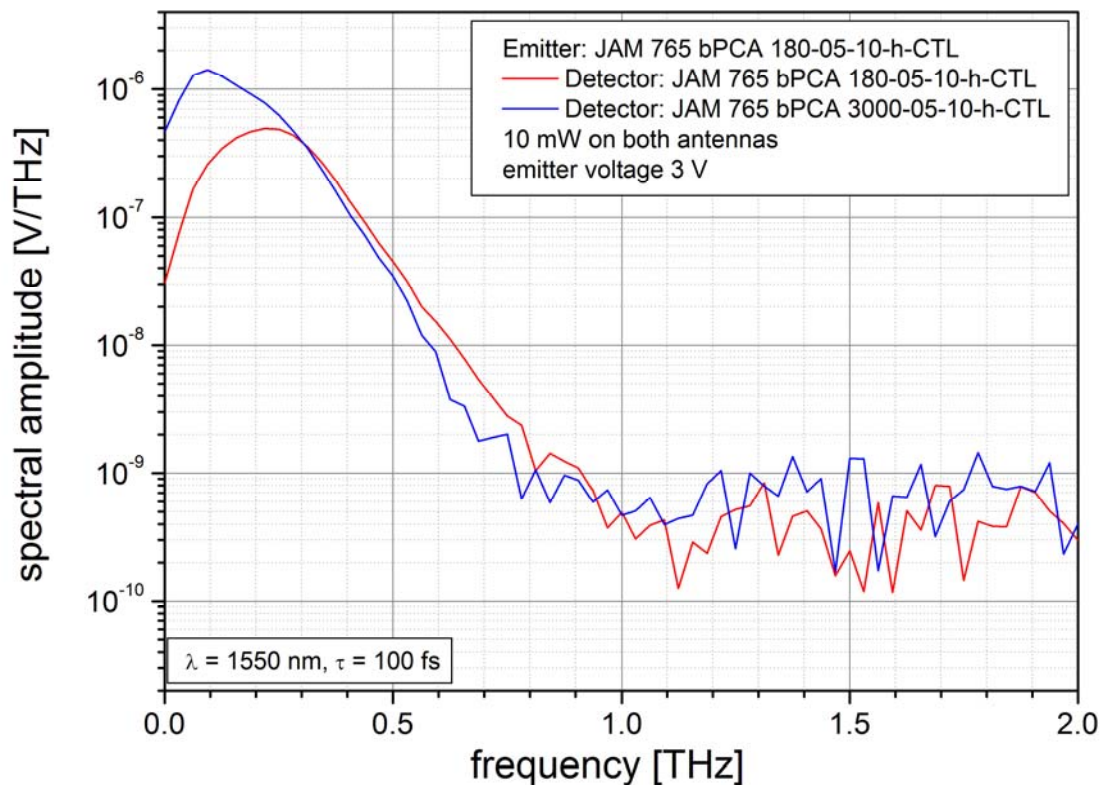
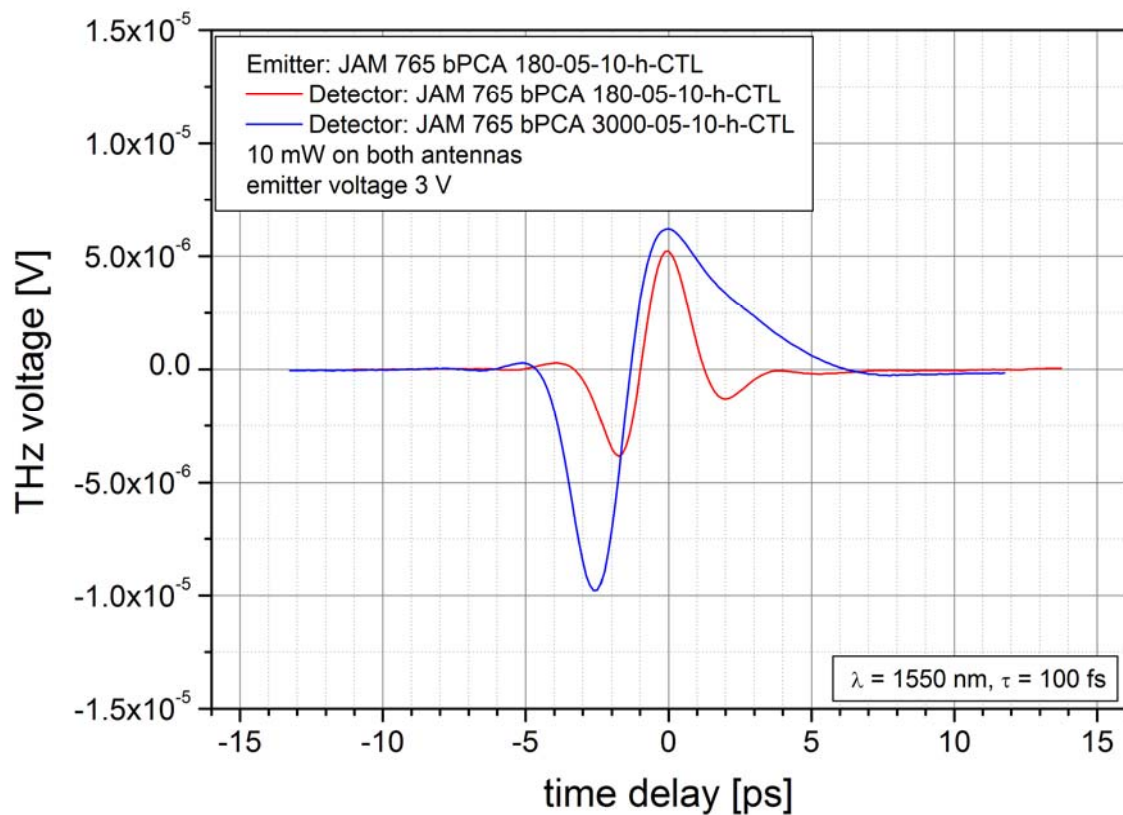

2. Antenna parameters

Parameter	minimum ratings	standard	maximum ratings
Dark resistance	2.0 kΩ	3.5 kΩ	5 kΩ
Voltage		3 V	3 V
Optical mean power @ 50 – 100 MHz repetition rate		8 mW	10 mW
Pulse fluence		200 μJ/cm ²	250 μJ/cm ²

Attention: The F-number of the optical lens focusing the laser beam onto the antenna gap must be larger than a certain value to avoid too high pulse fluency. This means, that the minimum diameter of the focused beam waist must be about 120 % of the gap distance g . For a Gaussian beam the minimum focus length f_{\min} of the optical lens can be estimated as

$$f_{\min} = \frac{0.3 \cdot \pi \cdot g \cdot D}{\lambda}$$

with g – gap distance of the antenna

λ - laser wavelength

D – diameter of the laser beam hitting the focusing lens.

For $\lambda = 1,5 \mu\text{m}$ and $g = 5 \mu\text{m}$ the minimum possible F-number of the lens is $f_{\min}/D = \pi$.

Current-voltage characteristics

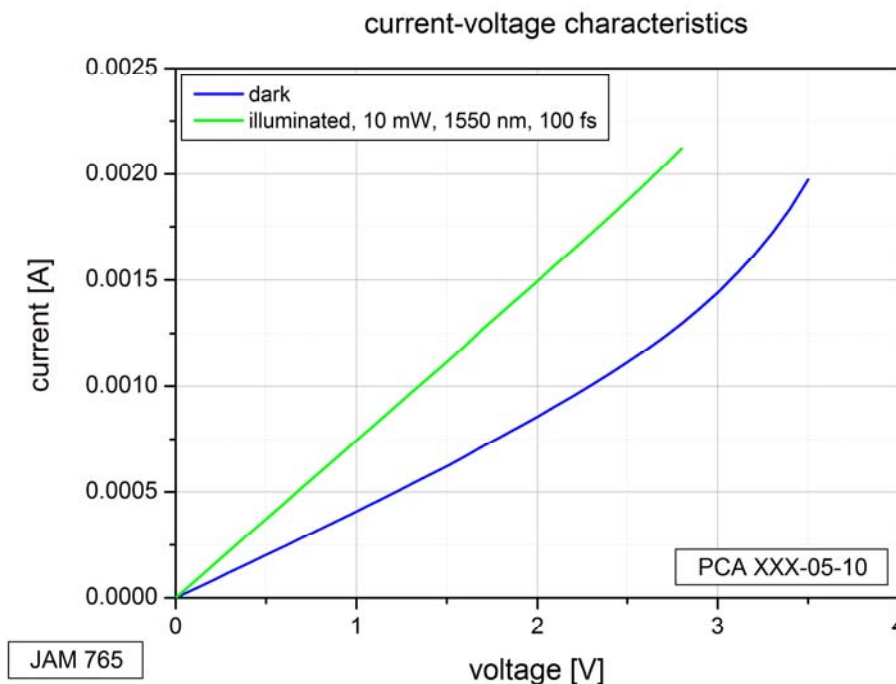

3. Antenna design

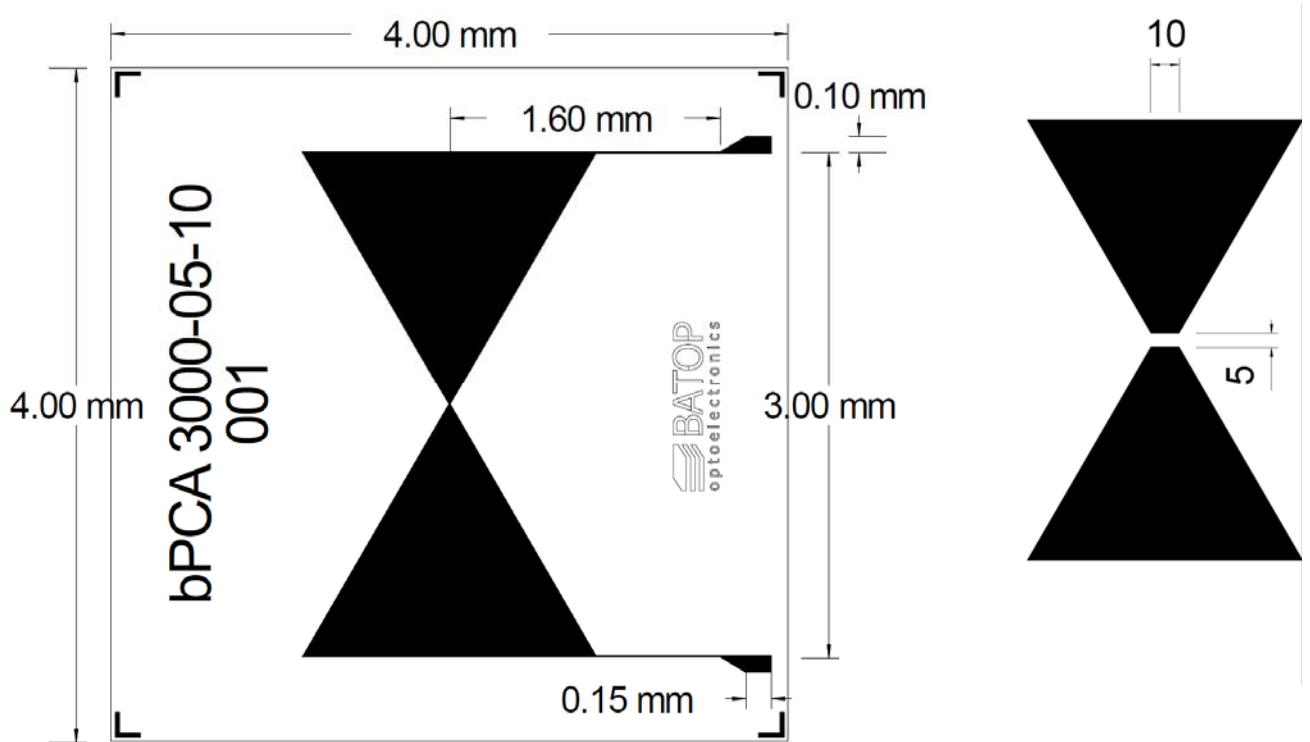

gap dimensions in μm

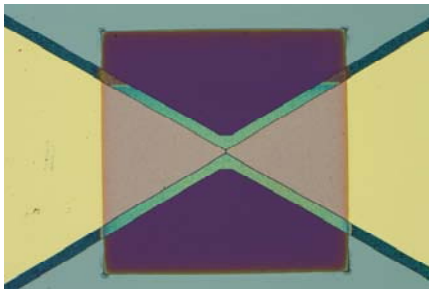

bPCA 3000-05-10-1550

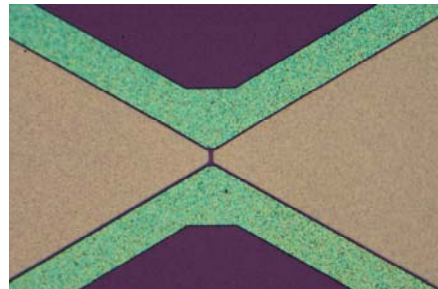

bPCA 3000-05-10-1550 (detail)

4. Order information

bPCA-3000-05-10-1550-x Photoconductive antenna
 length $l = 3000 \mu\text{m}$
 gap $g = 5 \mu\text{m}$
 width $w = 10 \mu\text{m}$
 laser wavelength $\lambda = 1550 \text{ nm}$

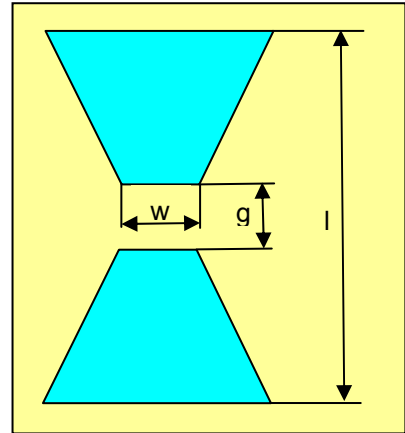

x denotes the type of mounting as follows:

- x = 0** unmounted chip 4 mm x 4 mm with 2 bond contact pads
- x = h** mounted on an Al disc with 25.4 mm \varnothing and [hyperhemispherical silicon substrate lens](#), 1m coaxial cable with BNC or SMA connector
- x = a** mounted on an Al disc with 25.4 mm \varnothing and [aspheric focusing silicon substrate lens](#), 1m coaxial cable with BNC or SMA connector
- x = c** mounted on an Al disc with 25.4 mm \varnothing and aspheric collimating silicon substrate lens CL-12 for 12 mm THz beam diameter, 1m coaxial cable with BNC or SMA connector
- x = h-f** [fiber coupled antenna](#) with hyperhemispherical silicon substrate lens
- x = l** with [aspheric focusing optical lens](#) for free space laser excitation
- x = p** with [preamplifier](#) for detector antenna

For information about THz beam guiding possibilities please [click here](#)